

Multi-application - LiFePO4 Power

CE UE-24Li300

Issued Date > 2016-08-05

Issued Version > V01

LITHIUM IRON PHOSPHATE BATTERY



1. General Information

This specification defines the performance of rechargeable LiFePO4 battery pack **UE-24Li300** manufactured by UPOWER, S.L., describes the type, performance, technical characteristics, warning and caution of the battery pack.

2. Specification (@Battery initial Temp $25\pm 5^{\circ}\text{C}$)

NO.	Items	Criteria
1	Rated Capacity	300Ah
	Minimum Capacity	285Ah
2	Energy	7.68KWh
3	Nominal Voltage	25.6V
4	Outgoing Voltage	$\geq 25.6\text{V}$
5	Internal resistance	$\leq 20\text{m}\Omega$
6	Limited charge voltage	$29.2\pm 0.2\text{V}$
7	Floating charge voltage	$27.6\pm 0.2\text{V}$
8	Standard charge current	60A
9	Maximum charge current	100A
10	Standard discharge current	100A
11	Maximum discharge current	150A/Continuous for 1 hour
12	Pulse discharge current	200A/Continuous for 15 min
13	Discharge cut-off voltage	20V



NO.	Items	Description
14	Dimension	Length: 602±3mm
		Width: 530±3mm
		Height: 202±3mm
15	Weight	Approx: 85.0±1.0Kg
16	Operating Temperature	Charging: 0~45°C
		Discharging: -20~60°C
		Recommended operating temperature: 15°C~35°C
17	Self-discharge rate	Residual capacity: ≤3%/month; ≤15%/years
		Reversible capacity: ≤1.5%/month; ≤8%/years
18	Storage Temperature & Humidity Range	Less than 1 month: -20°C~35°C, 45% RH~75% RH
		Less than 3 months: -10°C~35°C, 45% RH~75% RH
		Recommended storage environment: 15°C~35°C, 45% RH~75% RH

Long time storage:

If the battery need be stored for a long time, the voltage should be 25.6V (50% SOC), and stored in the condition as storage proposal. It need at least one charge & discharge cycle every six months

3. Test Conditions

3.1 Standard Test Conditions

3.1.1 Unless otherwise specified, all performance tests is required conducted at temperature 25°C±2°C, Humidity less than 45% ~ 75% RH.

3.1.2 Unless otherwise specified, the tested product is required unused within two month after outgoing.

3.2 Standard Charge Mode

"Standard Charge" means at 25±2°C charge to limit voltage with 0.33C constant current, then charge with constant voltage until current less than 0.02ItA.

3.3 Quick Charge Mode

"Quick Charge" means at 25±2°C charge to limit voltage with 0.5 C constant current, then charge with constant voltage until current less than 0.02ItA.

3.4 Standard Discharge Mode

"Standard Discharge" means at 25±2°C discharge to the cut-off voltage with 0.33C current.

3.5 Quick Discharge Mode

"Quick Discharge" means discharge to the cut-off voltage with 0.5C current.



4. Product Performance

NO.	Items	Criterion	Testing method	
1	Rated Capacity	300Ah	Rest for 1 hour after fully charged, then discharge with 0.33C current until the battery reaches the discharge cutoff voltage. Repeat above process for three times, if the discharge time is not less than 120 minutes, you can stop and define the Discharging current*time value (Ah) as battery capacity.	
2	Minimum Capacity	285Ah		
3	Internal resistance	≤20mΩ	50% battery SOC state frequency of 1 KHZ ac resistance tester.	
4	Cycle life (DOD%100)	≥2500 cycles	Discharge with the current of 0.33C until it can't discharge, and then rest it for 1h. Charge the battery following CC (0.33C)/CV (14.6V) mode to full capacity, and then rest it for 1h. Repeat above process until full charged capacity is no more than 80% of normal value. Accumulated times is defined as cycle life.	
5	Discharge Temperature Characteristics	-20°C	≥70%	At 25±5°C discharge the battery with the current of 0.33C to the cut-off voltage. Store the battery at various temperatures for 2h and discharge the battery with 0.33C to the cut-off voltage.
		0°C	≥80%	
		25°C	≥100%	
		55°C	≥95%	
6	Charge Retention ability	Residual capacity ≥80%	Charge the battery to full capacity and store it for 28 days, and then discharge it with 0.33C to the cut-off voltage.	
		Recovery capacity ≥90%		

5. Protective Circuit Specification

The batteries are supplied with a LiFePO4 Battery Management System (BMS) that can monitor and optimized each single prismatic cell during charge & discharge, to protect the battery pack overcharge, over discharge, short circuit. Overall, the BMS helps to ensure safe and accurate running.

Items	Content	Specification
Over charge	Over-charge protection for each cell	3.80±0.03V
	Over-charge release for each cell	3.60±0.05V
	Over-charge release method	Under the release voltage



Items	Content	Specification
Over discharge	Over-discharge protection for each cell	2.50±0.05V
	Over-discharge release for each cell	3.00±0.05V
	Over-discharge release method	Charging recovery
Over current	Discharge over current protection	550±50A
	Protection delay time	50~150ms
	Over current release method	Release after cutoff the load
Short	NO	Ban electrode short circuit
Battery temperature	Charge over temperature	Protection @55±5°C
		Release @45±5°C
	Discharge over temperature	Protection @65±5°C
		Release @55±5°C
	Charge low temperature	Protection @0±5°C
		Release @10±5°C
	Discharge low temperature	Protection @-20±5°C
		Release @-10±5°C
MOSFET over temperature	Protection @100±5°C	
	Release @90±5°C	
LCD Screen	Short press a switch, light and display screen: voltage temperature residual capacity current, light up after waiting for screen to go out, after 60s into power saving state (buzzer open state, the buzzer alarm detection background), short press it again to light up the screen.	
Buzz	Buzzer open state: SOC 10% or less, buzzer alarm, long press switch 3s, buzzer close and screen OFF buzzer hints.	
	Buzzer is turned off, when the SOC 50% or less, need to manually by 3s starting buzzer long (SOC testing and determine whether the alarm).	
	Buzzer is turned off, charging when the battery pack is SOC > 50%, the buzzer closed automatic reset, in an open position.	



6. Dimensional Drawing

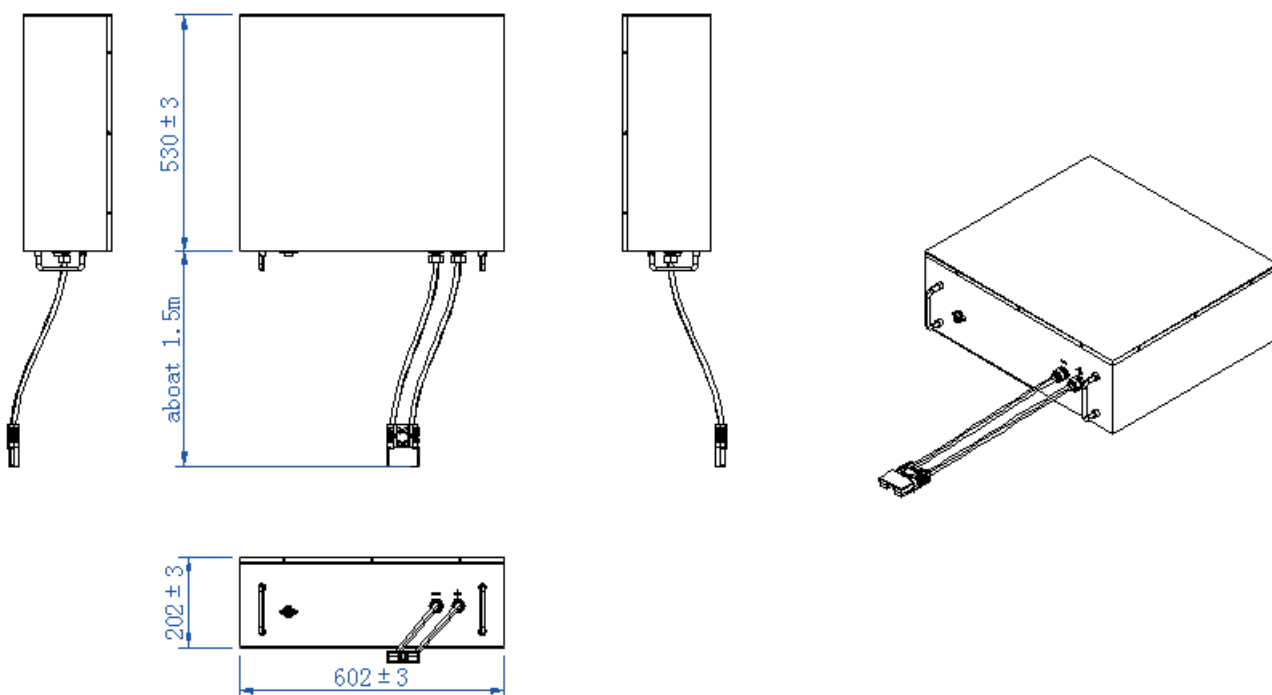

7. 4P - Air head Pin definition (main board and display)

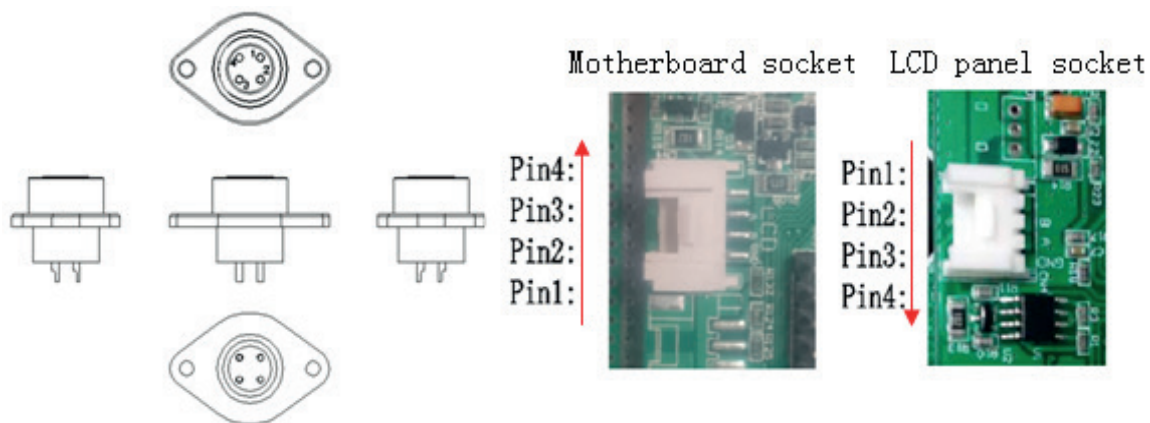

1. The motherboard socket: Pin1 to 12V+, Pin2 to B, Pin2 to A and Pin4 to GND.
2. The LCD panel socket: Pin1 to 12V+, Pin2 to B, Pin2 to A and Pin4 to GND.
3. Battery iron box matching LCD communication shielding line length is about 1.5 m.



8. Transportation

- Based on the character of cell, proper environment for transportation of LiFePO₄ battery pack need to be created to protect the battery.
- Battery should be stayed in the warehouse 15°C ~ 35°C where it's dry, clean, shade and well-ventilated.
- The battery should be stored in 50% SOC during transportation (**the suggest method: Charge the battery fully 29.2V, and discharge the battery until reaches the discharge cutoff voltage 20.0V, then charge the battery up to 50% SOC 26.4V and storage in proper circumstance according specification**).
- The battery need to be charged every 6 months if out of use.
- Keep the battery against dropping, turning over and serious stacking during loading.

9. Warning & Tips

Please read and follow the specification and caution remarks on battery surface before use the battery. Improper use may cause heat, fire, rupture, damage or capacity deterioration of the battery. UPOWER S.L. describes is not responsible for any accidents caused by the usage without following our specification.

- The battery must be far away from heat source, high voltage, and avoid to be exposed in sunshine for long time.
- Never throw the battery into water.
- Do not put the battery in a charger or equipment with wrong terminals connected.
- Never connect the positive and negative of battery with metal.
- Avoid excessive physical shock or vibration. don't hit, fall, stamp on the battery.
- Without the permission of the manufacturer and guidance, forbidden to remove or to assemble the battery.
- Do not use the battery mixed with other different manufacturer, type, or model batteries.
- Keep the battery against high temperature. Otherwise it will cause battery heat, get into fire or lose some function and reduce the life.
- When battery run out of power, please charge your battery timely (≤ 15 day).
- Please use the matched or suggested charger for this battery.
- If battery emit peculiar smell, heating, distortion or appear any abnormality during working or storage, please stop using and take it out from device.
- If the battery leaks and get into the eyes or skin, do not wipe, instead, rinse it with clean water and see doctor immediately.
- Please far away from children or pets.
- Do not put disuse battery into a fire or water.
- It is strictly prohibited any series between the battery packs. Any requirements on serials connection, please contact to UPOWER, S.L. for details.



10. Battery Operation Instruction

10.1 Charge and discharge

10.1.1 Charging current: Do not surpass the largest charging current that specification stipulated.

10.1.2 Charging voltage: Do not surpass the highest limited voltage that specification stipulated.

10.1.3 Charging temperature: within temperature scope that specification stipulated.

10.1.4 Charge with constant current, then with the constant voltage, no reverse charge, which is dangerous.

10.1.5 Special note:

Short time doesn't affect the use of the battery overcharge too, but for a long period of time over discharge or over charge can affect the function of the battery failure, or the battery can't use permanent, appear serious safety hazards, need long time floating please use the recommended floating model specification. Battery when not in use for a long time, because of its own self-discharge characteristics can also cause discharge, to prevent the occurrence of a discharge, battery should maintain a certain capacity, maintain the voltage at 50% state of SOC.

11. Other Chemical Reaction

Because batteries utilize a chemical reaction, battery performance will deteriorate over time even if stored for a long period of time without being used. In addition, if the various usage conditions such as charge, discharge, ambient temperature, etc. are not maintained within the specified ranges, the life expectancy of the battery may be shortened or the device in which the battery is used may be damaged by electrolyte leakage. If the discharge time is much shorter than the normal after full charged, even battery is charged correctly, and this may indicate it is time to change the battery.

